

Hydratech Industries
Wind Power

Your Turbine in
Safe Hands

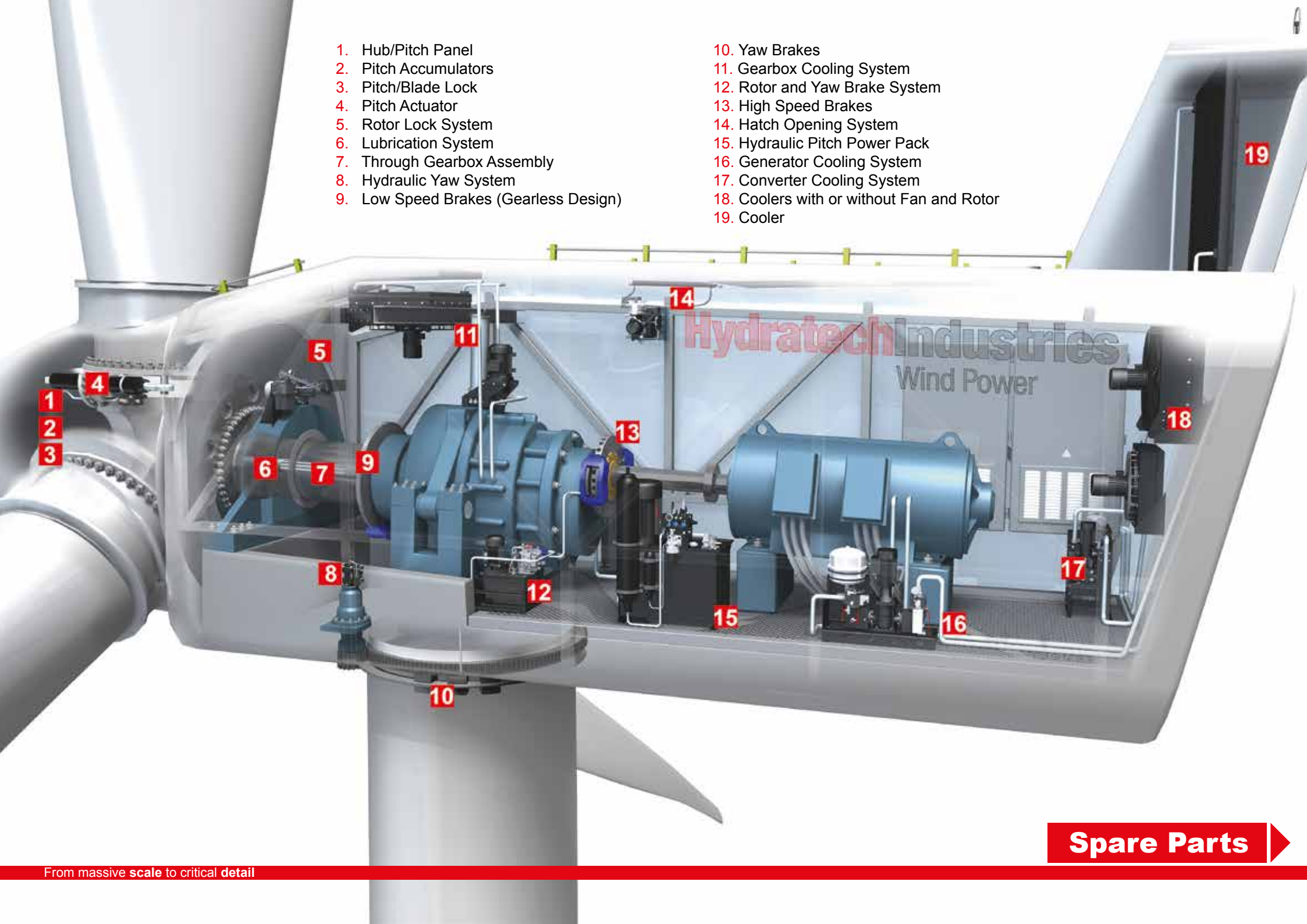

1. Hub/Pitch Panel
2. Pitch Accumulators
3. Pitch/Blade Lock
4. Pitch Actuator
5. Rotor Lock System
6. Lubrication System
7. Through Gearbox Assembly
8. Hydraulic Yaw System
9. Low Speed Brakes (Gearless Design)
10. Yaw Brakes
11. Gearbox Cooling System
12. Rotor and Yaw Brake System
13. High Speed Brakes
14. Hatch Opening System
15. Hydraulic Pitch Power Pack
16. Generator Cooling System
17. Converter Cooling System
18. Coolers with or without Fan and Rotor
19. Cooler



Spare Parts 2.3 MW Turbine

Item No. B4194
Pitch Pal Cylinder

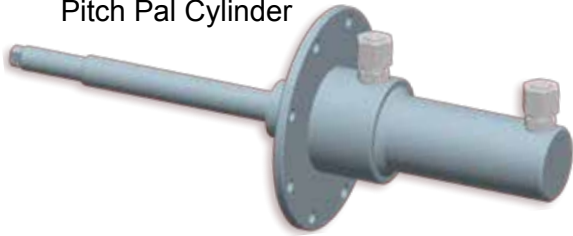

Item No. B3740
Hatch Cylinder



Item No. B3738
Pitch Cylinder w/Transducer



Item No. B3739
Pitch Cylinder wo/Transducer



Item No. B4214
20L Accumulator for Hub, w Throttle



Item No. B3737
Pitch Manifold Complete

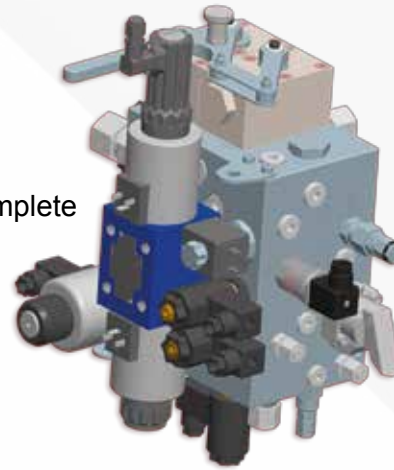

Item No. B3716
Distribution Manifold

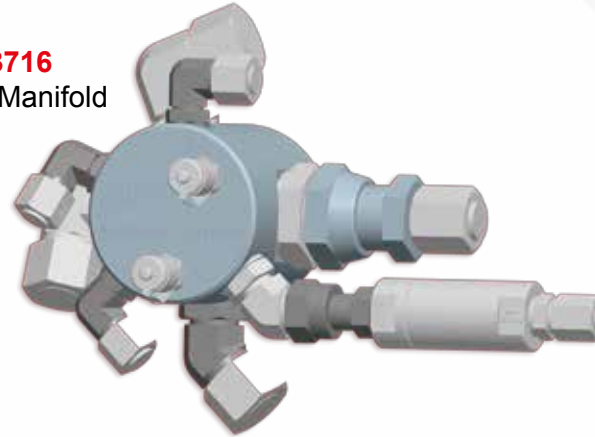

Item No. B4500
Pitch Power Pack,
facelift 50 Hz

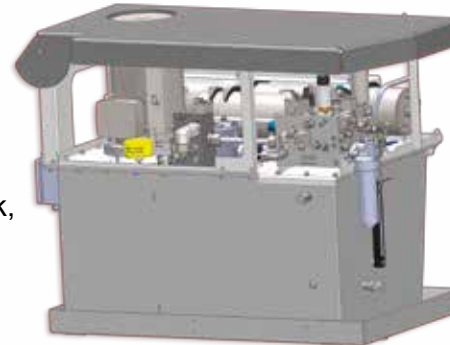

Item No. B4255
Accumulator Tubes



Item No. B3733
Hatch Valve

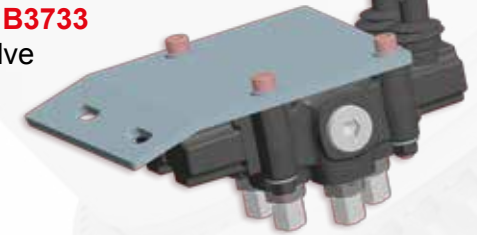

Item No. B4128
Hand Pump

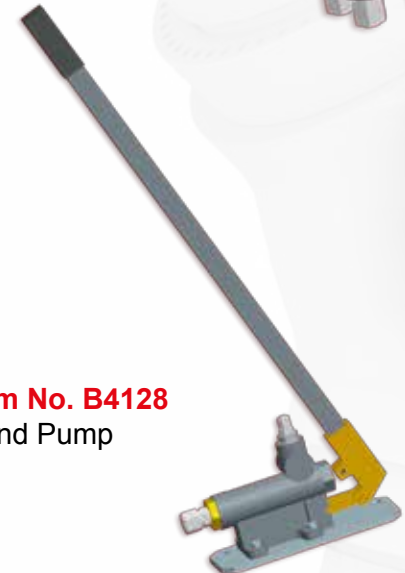

Spare Parts 3.6 MW Turbine

Item No. B2987
Pitch Pal Cylinder



Item No. B4349
Blade Hydraulics



Item No. B4346
Yaw Brake Hydraulic

Item No. B4420
Hatch Cylinder

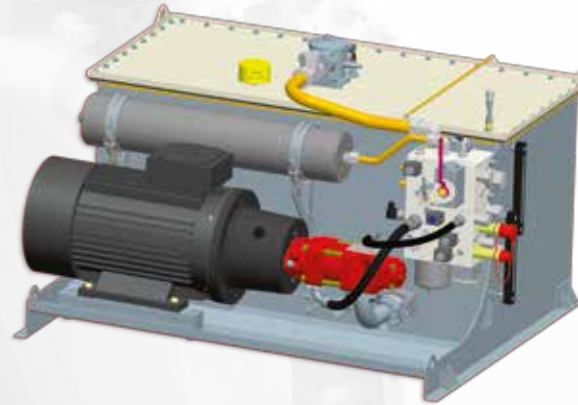

Item No. B4000
Pitch Power Pack



Item No. B4473
HS Brake Hydraulic

Item No. B4377
Pitch Cylinder w/Transducer



Item No. B4429
Accumulator Pack

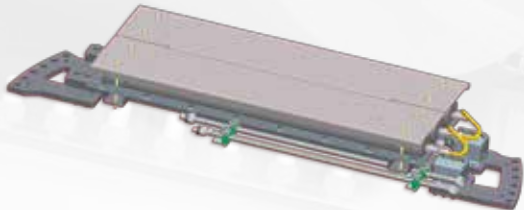

Item No. B3061
TGA Parts

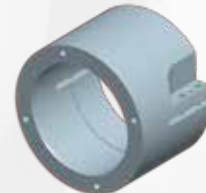

Item No. B3062
TGA Parts

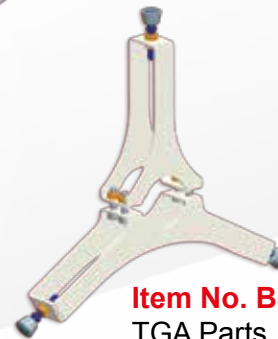

Item No. B3063
TGA Parts

Item No. B3542
TGA Parts



Item No. B3926
Hatch Power Pack

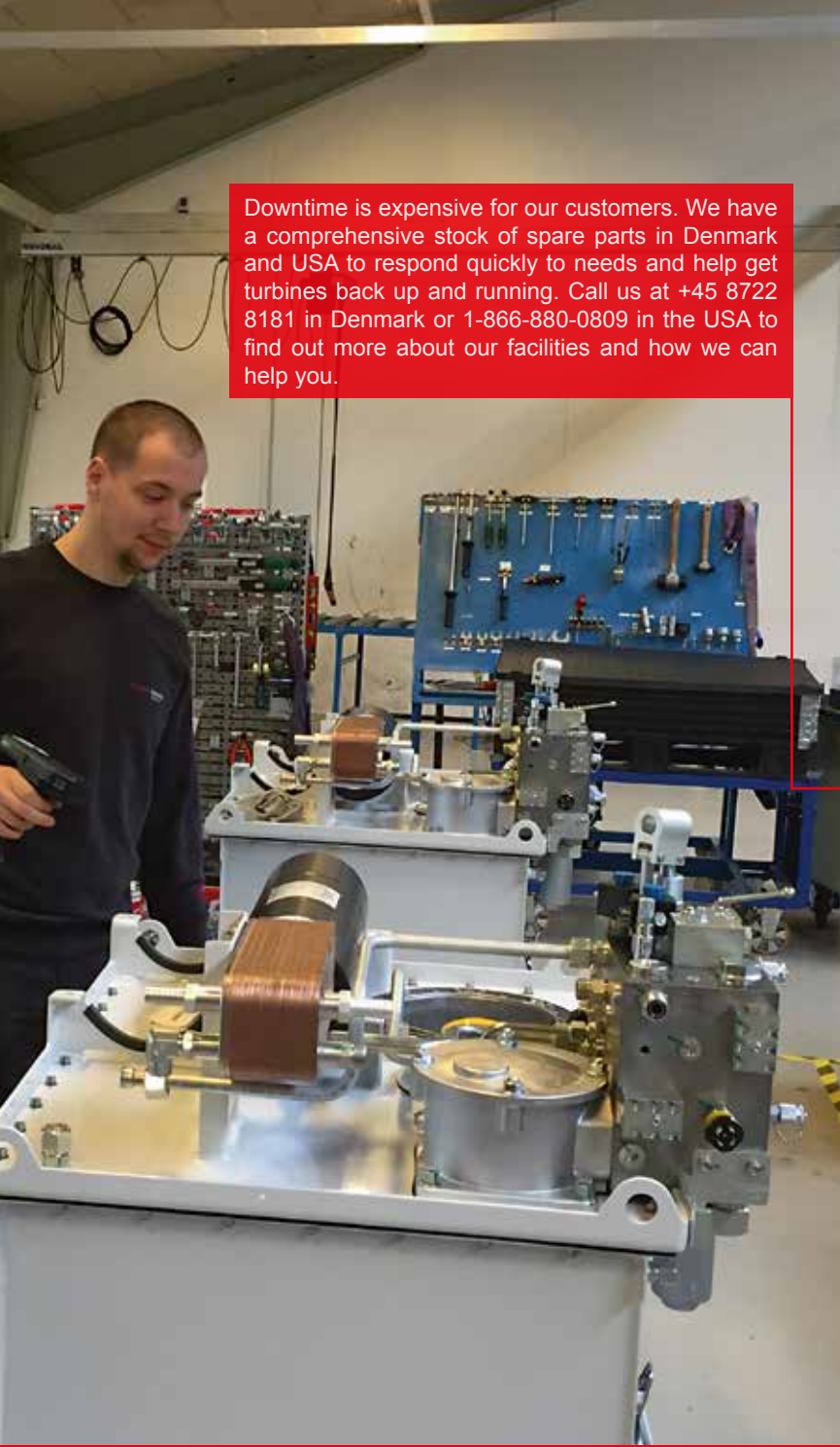

Downtime is expensive for our customers. We have a comprehensive stock of spare parts in Denmark and USA to respond quickly to needs and help get turbines back up and running. Call us at +45 8722 8181 in Denmark or 1-866-880-0809 in the USA to find out more about our facilities and how we can help you.

Dedicated to Servicing and Repairing Wind Turbine Hydraulic Parts Globally

Hydratech Industries Wind Power is expert in design, production and service and repair of hydraulic and cooling solutions. With thirty years of experience in manufacturing, our global service and repair team can provide:

- Fast, dependable repair
- Quick turnaround with large spare part inventory
- Retrofit designs providing solutions to current problems
- Upgrades to improve performance, including bladder accumulators to complete piston accumulators
- Routine service to prevent unscheduled downtime

Global Footprint To Service Our Customers

With two service and repair locations, three manufacturing facilities and two research and development departments we are ready to offer a dedicated, customized efficient global service to our customers.

Quality and Inspection

To keep the quality of work to the highest standards each component undergoes a rigorous inspection process. All aspects of the inspection and dismantling are recorded in a detailed report

Inspection Process

- Inspection process is completed in pressurized clean room facilities
- Visual inspection
- Sealing systems are upgraded to the newest standard
- Damaged parts are replaced or repaired
- Fluid leakage is checked as well as components
- Assembly and testing are completed in positive air pressure clean rooms.



Hydratech Industries Wind Power is committed to continuous improvement and are certified ISO 9001:2008, ISO 14001:2008 Quality Management System and DS/OHSAS 8001:2008.

Global Service Organization



Bjarne Nyborg Nielsen, DK
bny@hydrattech-industries.com

Bjarne is our Global Service Manager, and has more than 25 years of experience within the wind turbine industry. First as a technician and now more than 20 years in global service management.



Tina Dalstrup Jakobsen, DK
tdj@hydrattech-industries.com

Tina has a commercial background with more than 25 years of experience from larger global sales organizations. Coordinating orders, requests, prices, sales material and multiple other tasks.



Lars Dissing Andersen, USA
lda@hydrattech-industries.com

Lars has both a technical and commercial background, and altogether more than fifteen years of wind turbine experience. Lars is Head of Operations for the US part of the global service team.



Martin Villadsen, DK
mkv@hydrattech-industries.com

Martin has many years of experience within wind turbine industry and is responsible for our workshop team regarding repairs, testing, site visits etc.



Charlotte Lund Grønbaek, DK
clg@hydrattech-industries.com

Charlotte is assisting the team in registration of repairs, handling orders and multiple other tasks.



Mickey Gilbert, USA
mag@hydrattech-industries.com

Mickey has a technical background and more than twenty years of experience in industrial sales and sales management, and as such anchoring the US team in house regarding all service related task.



Steen Hjorth, DK
sh@hydrattech-industries.com

Steen has a technical background and he has worked with sales and consulting for hydraulic equipment for the wind industry and automation industry for more than 25 years.



Camilla Hammerholt Jensen, DK
cmj@hydrattech-industries.com

Camilla is responsible for updating and uploading Hydrattech spare parts for web sales, but also for supporting the team on a daily basis regarding request and orders.



Greg Myers, USA
gm@hydrattech-industries.com

Greg is our Wind Power Sales Manager responsible for Wind Power Sales West US. He has twenty plus years of experience in industrial sales and management.



Morten Bundgaard, DK
mob@hydrattech-industries.com

Morten has a technical and commercial background and more than 20 years of experience with the OEM wind power industry.



Janna Young, USA
jy@hydrattech-industries.com

Janna Young served three years in the United States Air Force prior to joining Hydrattech Industries. Janna is assisting the US team of Hydrattech Industries with a wide range of administrative tasks.

Contact

Denmark

Suensonsvej 14
DK-8600 Silkeborg
servicehwp@hydrattech-industries.com
Tel.: +45 8722 8181

Germany

Raboisen 38
20095 Hamburg
ge@hydrattech-industries.com
Tel.: +49 40 2109127 0

USA

P.O. Box 2618
22955 McAuliffe Dr.
Robertsdal, AL 36567
usa@hydrattech-industries.com
Tel.: +1 251 947 5300

India

No. 161, Basavangar Main Road
Bengaluru 560037
india@hydrattech-industries.com
Tel.: +91 80 4050 6999

China

No. 53 Jiepu Road
Shenpu Development Zone
Suzhou SIP 215 216
china@hydrattech-industries.com
Tel.: +86 512 6281 3668